

HITACHI

ZX210LC-7 | Preliminary ZAXIS-7 series

Reliable Solutions



ZAXIS210

HYDRAULIC EXCAVATOR

Model code: ZX210LC-7H

Engine rated power, net: 164 hp (122.0 kW)

Operating weight: 49,833–50,936 lb. (22,600–23,100 kg)

Bucket capacity: 0.67–1.56 yd³ (0.51–1.20 m³)

SPECIFICATIONS

ENGINE	
Model	Isuzu 4HK1
Type	4-cycle water-cooled, common rail direct injection
Aspiration	Variable geometry turbocharged, intercooled, cooled EGR
Aftertreatment	DOC + SCR system
No. of cylinders	4
Rated power	
ISO 14396: 2002 gross	172 hp (128.4 kW) at 2,000 min ⁻¹
ISO 9249: 2007 net	164 hp (122.0 kW) at 2,000 min ⁻¹
Maximum torque	494 lbf (670 Nm) at 1,600 min ⁻¹
Piston displacement	316.898 cu .in. (5.193 L)
Bore and stroke	4.5" x 4.9" (115 mm x 125 mm)
Batteries	2 x 12 V/126 Ah

HYDRAULIC SYSTEM			
Hydraulic Pumps			
Main pumps	3 variable displacement axial piston pumps		
Maximum oil flow	2 x 56 gal/min (212 L/min)		
	1 x 49 gal/min (184 L/min)		
Pilot pump	1 gear pump		
Maximum oil flow	8.9 gal/min (33.7 L/min)		
Hydraulic Motors			
Travel	2 variable displacement axial piston motors		
Swing	1 axial piston motor		
Relief Valve Settings			
Implement circuit	4,974.8 psi (34.3 MPa)		
Swing circuit	4,699.2 psi (32.4 MPa)		
Travel circuit	4,974.8 psi (34.3 MPa)		
Pilot circuit	565.6 psi (3.9 MPa)		
Power boost	5,511.4 psi (38.0 MPa)		
Hydraulic Cylinders			
	Quantity	Bore	Rod diameter
Boom	2	4.7" (120 mm)	3.3" (85 mm)
Arm	1	5.3" (135 mm)	3.7" (95 mm)
Bucket	1	4.5" (115 mm)	3.2" (80 mm)

UPPERSTRUCTURE	
Revolving Frame	
D-section frame for resistance to deformation.	
Swing Device	
Axial piston motor with planetary reduction gear is bathed in oil. Swing circle is single-row. Swing parking brake is spring-set/hydraulic-released disc type.	
Swing speed	11.4 min ⁻¹
Swing torque	50,154 lbf (68.0 kNm)

UNDERCARRIAGE	
Tracks	
Tractor-type undercarriage. Welded track frame using selected materials. Side frame welded to track frame. Lubricated track rollers, idlers, and sprockets with floating seals. Track shoes with triple grousers made of induction-hardened rolled alloy. Heat-treated connecting pins with dirt seals. Hydraulic (grease) track adjusters with shock-absorbing recoil springs.	
Numbers of Rollers and Shoes on Each Side	
Upper rollers	2
Lower rollers	8
Track shoes	49
Track guards	3
Travel Device	
Each track driven by 2-speed axial piston motor. Parking brake is spring-set/hydraulic-released disc type. Automatic transmission system: High-Low.	
Travel speeds	High: 0 to 3.4 mph (0 to 5.5 km/h)
	Low: 0 to 2.2 mph (0 to 3.5 km/h)
Maximum traction force	45,636 lbf (203 kN)
Gradeability	70% (35 degree) continuous

SERVICE REFILL CAPACITIES	
Fuel tank	105.6 gal (400.0 L)
Engine coolant	7.4 gal (28.0 L)
Engine oil	6.1 gal (23.0 L)
Swing device	1.8 gal (6.9 L)
Travel device (each side)	1.8 gal (6.8 L)
Hydraulic system	63.4 gal (240.0 L)
Hydraulic oil tank	35.6 gal (135.0 L)
DEF/AdBlue® tank	15.0 gal (57.0 L)

ENVIRONMENT	
Engine Emissions	EPA Final Tier 4 / EU Stage IV
Sounds Level	
Sound level in cab according to ISO 6396: 2008	LpA 70 dB(A)
External sound level according to ISO 6395: 2008 and EU Directive 2000/14/EC	LwA 101 dB(A)

WEIGHTS AND GROUND PRESSURE

Operating Weight and Ground Pressure

			ZX210LC-7H *1	
Boom type			Monoblock	
Shoe type	Shoe width inch (mm)	Arm length ft-in (m)	lb (kg)	psi (kPa)
Triple grouser	32" (800)	9'7" (2.91)	50,927 (23,100)	5.22 (36)

*1 Including 1.05 yd³ (0.80 m³) (ISO 7451: 2007 heaped) bucket weight, 1,455 lb (660 kg) and counterweight, 10,692 lb (4,850 kg).

BASIC MACHINE WEIGHT AND COMPONENTS WEIGHT

Basic Machine Weight and Overall Width

Excluding front end attachment, fuel, hydraulic oil and coolant etc. Including counterweight.

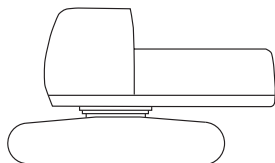

		ZX210LC-7H	
Shoe type	Shoe width in (mm)	Weight lb (kg)	Overall width in (mm)
Triple grouser	32" (800)	40,572 (18,400)	10' 6" (3 190)

Components Weight

Unit: lb (kg)

	ZX210LC-7H
Counterweight	10,692 (4,850)
Monoblock boom (with arm cylinder and boom cylinder)	4,850 (2,200)
Arm 9' 7" (2.91 m) (with bucket cylinder)	2,447 (1,110)
Bucket ISO 7451: 2007 1.05 yd ³ (0.80 m ³)	1,455 (660)

BUCKET AND ARM DIGGING FORCE

Unit: lbf (kN)

	ZX210LC-7H
Arm length	9' 7" (2.91 m)
Bucket digging force* ISO 6015: 2006	35,520 (158)
Arm crowd force* ISO 6015: 2006	25,628 (114)

* At power boost

SPECIFICATIONS

ZX210LC-7H

WORKING RANGES

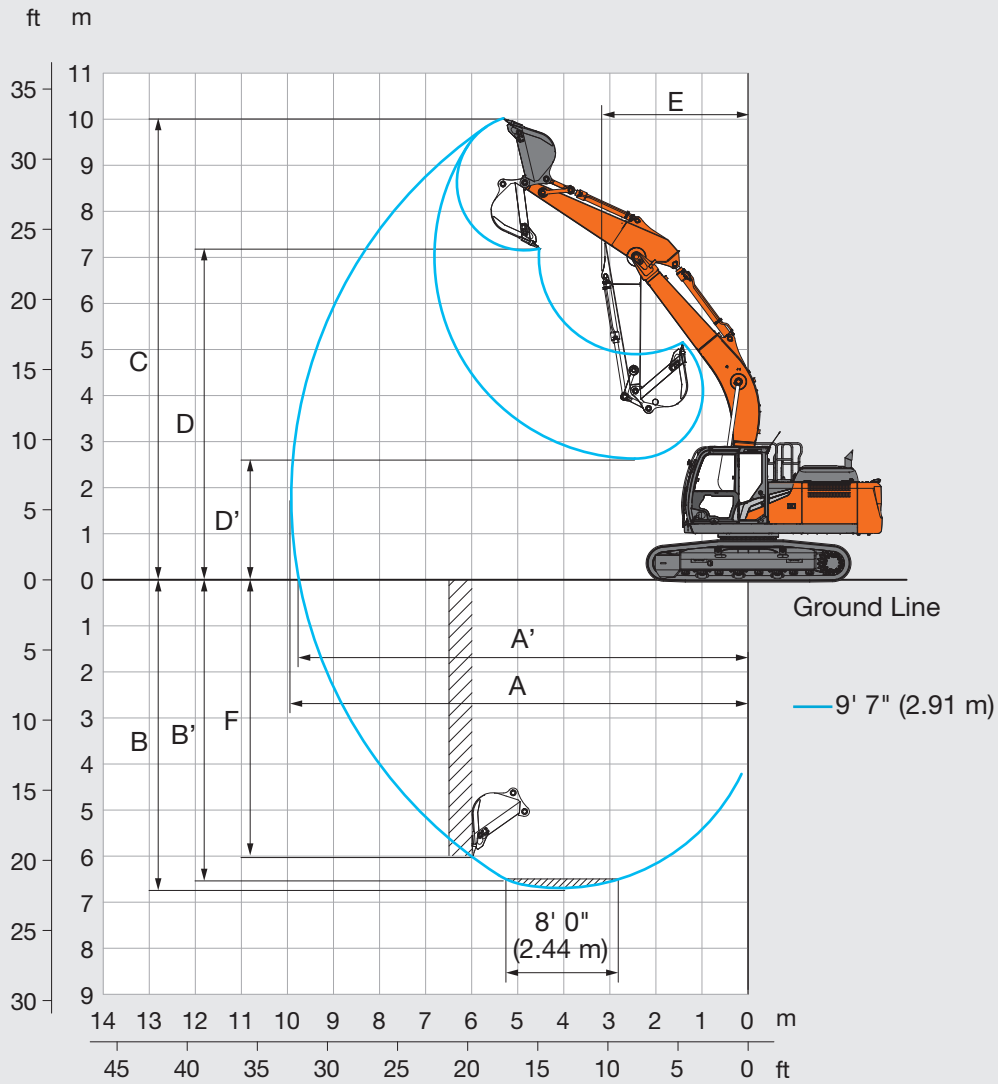

Unit: ft-in (mm)

	ZX210LC-7H
	Monoblock boom
Arm length	9' 7" (2,91 m)
A Max. digging reach	32' 7" (9,920)
A' Max. digging reach (on ground)	31' 12" (9,750)
B Max. digging depth	21' 11" (6,670)
B' Max. digging depth for 8' 0" (2.44 m) level	21' 3" (6,480)
C Max. cutting height	32' 11" (10,040)
D Max. dumping height	23' 7" (7,180)
D' Min. dumping height	8' 8" (2,650)
E Min. swing radius	10' 5" (3,180)
F Max. vertical wall digging depth	19' 8" (5,990)

Excluding track shoe lug

DIMENSIONS

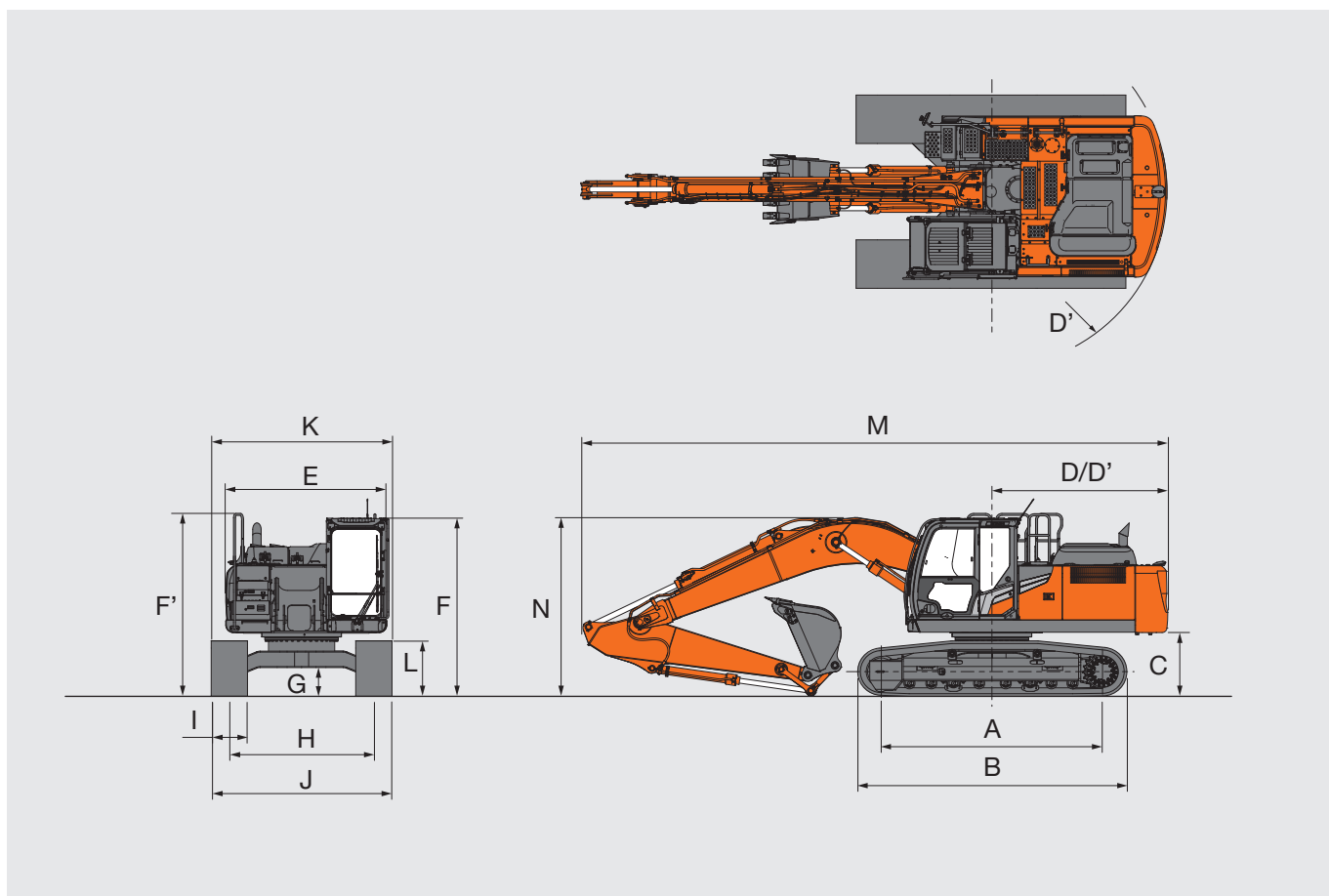

Unit: ft-in (mm)

	ZX210LC-7H
	Monoblock boom
A	Distance between tumblers
B	Undercarriage length
*1 C	Counterweight clearance
D	Rear-end swing radius
D'	Rear-end length
E	Overall width of upperstructure
F	Overall height of cab
F'	Overall height of handrail
*1 G	Min. ground clearance
H	Track gauge
I	Track shoe width
J	Undercarriage width
K	Overall width
*1 L	Track height with triple grouser shoes
M	Overall length with 9' 7" (2.91 m) arm
N	Overall height of boom with 9' 7" (2.91 m) arm

*1 Excluding track shoe lug G: Triple grouser shoe

MACHINE CAPACITIES

ZX210LC-7H

- Notes:
1. Ratings are based on ISO 10567: 2007.
 2. Machine capacity does not exceed 75% of tipping load with the machine on firm, level ground or 87% full hydraulic capacity.
 3. The load point is the center-line of the bucket pivot mounting pin on the arm.
 4. *Indicates load limited by hydraulic capacity.
 5. 0 ft (0 m) = Ground.
 6. Each machine capacities values are applicable when selecting optional attachment basic piping and hose rupture valve for boom and arm.

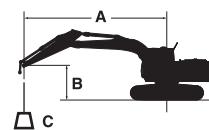

A: Load radius
 B: Load point height
 C: Machine capacity

For machine capacities, subtract installed attachment and quick hitch weight from machine capacities.

To determine lifting capacities, apply "Rating over-side or 360 degrees" machine capacities from the table and deduct weight of installed attachment and quick hitch. Optional feature may affect machine performance.

ZX210LC-7H MONOBLOCK BOOM

Rating over-front Rating over-side or 360 degrees Unit: lb (kg)

Conditions	Load point height ft (m)	Load radius										At max. reach		
		5 ft (1.5 m)		10 ft (3.0 m)		15 ft (4.5 m)		20 ft (6.0 m)		25 ft (7.5 m)				ft-in (meter)
Boom 18' 8" (5.68 m) Arm 9' 7" (2.91 m) Counterweight 10,692 lb (4,850 kg)	20' (6.0)							11,350* (5,170)*	11,350* (5,170)*			8,850* (4,000)*	8,850* (4,000)*	24' 0" (7.32)
	15' (4.5)					14,160* (6,550)*	14,160* (6,550)*	12,440* (5,710)*	12,440* (5,710)*	11,690* (5,320)*	9,110 (4,230)	8,710* (3,950)*	8,440 (3,800)	26' 3" (8.01)
	10' (3.0)					18,190* (8,440)*	18,190* (8,440)*	14,260* (6,570)*	12,340 (5,720)	12,400* (5,680)*	8,890 (4,120)	8,940* (4,060)*	7,710 (3,490)	27' 6" (8.37)
	5' (1.5)					21,930* (10,150)*	17,610 (8,160)	16,120* (7,430)*	11,800 (5,470)	13,130 (6,090)	8,640 (4,000)	9,550* (4,340)*	7,450 (3,380)	27' 9" (8.45)
	0 (Ground)			11,130* (4,810)*	11,130* (4,810)*	23,820* (11,000)*	16,980 (7,880)	17,360* (8,000)*	11,420 (5,290)	12,920 (5,990)	8,450 (3,910)	10,680* (4,840)*	7,590 (3,440)	27' 1" (8.25)
	-5' (-1.5)	12,210* (5,440)*	12,210* (5,440)*	20,630* (9,060)*	20,630* (9,060)*	23,770* (10,960)*	16,800 (7,800)	17,530* (8,090)*	11,260 (5,210)	12,860 (5,960)	8,400 (3,880)	12,580 (5,690)	8,230 (3,720)	25' 6" (7.76)
	-10' (-3.0)	22,340* (9,930)*	22,340* (9,930)*	30,830* (14,220)*	30,830* (14,220)*	21,840* (10,100)*	16,940 (7,860)	16,120* (7,490)*	11,340 (5,250)			13,580* (6,150)*	9,740 (4,390)	22' 8" (6.90)
	-15' (-4.5)			23,760* (11,090)*	23,760* (11,090)*	17,020* (8,000)*	17,020* (8,000)*					13,530* (6,150)*	13,530*	18' 1" (5.52)

EQUIPMENT

●: Standard equipment ○: Optional equipment -: Not applicable

ENGINE	ZX210LC-7H
Aftertreatment device	●
Air cleaner double filters	●
Alternator 60 A	●
Auto idle system	●
Auto shut-down control	●
Cartridge-type engine oil filter	●
Cartridge-type fuel main filter	●
Cold fuel resistance valve	●
ConSite OIL (sensor)*	●
DEF / AdBlue® tank	●
DEF / AdBlue® tank inlet strainer and extension filler	●
Dry-type air filter with evacuator valve (with air filter restriction indicator)	●
Dust-proof indoor net	●
ECO / PWR / HP mode control	●
Electrical fuel feed pump	●
Engine oil drain coupler	●
Expansion tank	●
Fan guard	●
Fuel cooler	●
Fuel pre-filter with water separator	●
Isolation-mounted engine	●
Maintenance free pre-cleaner	○
Radiator, oil cooler and intercooler	●

HYDRAULIC SYSTEM	ZX210LC-7H
Auto power lift	●
ConSite OIL (sensor)*	●
Control valve with main relief valve	●
High mesh full flow filter	●
Hose rupture valve for boom/arm and overload alarm	○
Pilot filter	●
Power boost	●
Restriction indicator for full flow filter	○
Suction filter	●
Swing dampener valve	●
Two extra ports for control valve	●
Variable relief valve for breaker and crusher	●
Work mode selector	●

CAB	ZX210LC-7H
All-weather sound suppressed steel cab	●
Auto control air conditioner	●
AUX function lever (breaker)	●
AUX function lever (breaker assist)	○
Bluetooth® integrated radio	●
Console height adjustment	●
Control lever auto-lock	●
CRES VII (center pillar reinforced structure) cab	●
Drink holder with hot and cool function	●
Electric double horn	●
Engine shut-off switch	●
Equipped with reinforced, tinted (green color) glass windows	●
Evacuation hammer	●
Floor mat	●
Footrest	●
Front window washer (2 points)	●
Glove compartment	●
Hands-free calling device	●
Hot and cool box	●
Intermittent windshield wipers	●
Key cylinder light	●
LED room light	●
Magazine rack	●
OPG front guard Level II (ISO 10262: 1998) compliant	○
OPG top guard Level I (ISO 10262: 1998) compliant	●
OPG top guard Level II (ISO 10262: 1998) compliant	○
Pilot shut-off lever	●
Power outlet 12 V and 24 V	●
Push button low idle	●
Rain guard (without OPG front guard)	●
Rear tray	●
Retractable seat belt 3 in. (76 mm)	●
ROPS (ISO 12117-2: 2008) compliant cab	●
Rubber radio antenna	●
Seat: air suspension seat with heater	●
Seat adjustment part: backrest, armrest, height and angle, slide forward / back	●
Seat belt reminder	●
Short wrist control levers	●
Smartphone holder	●
Straight travel pedal	○
Sunscreen roller type (multi-use front or side and rear window)	●
Transparent roof with slide curtain	●
USB power supply	●
Wide view wiper	●
Windows on front, upper, lower and left side can be opened	●
2 speakers	●
4 fluid-filled elastic mounts	●
8 inch monitor	●

●: Standard equipment ○: Optional equipment -: Not applicable

MONITOR SYSTEM	ZX210LC-7H
Alarm buzzers: overheat, engine oil pressure, overload, SCR system trouble, etc	●
Alarms: overheat, engine warning, engine oil pressure, alternator, minimum fuel level, hydraulic filter restriction, air filter restriction, work mode, overload, SCR system trouble, etc	●
Display of meters: water temperature, hour, fuel rate, clock, DEF / AdBlue® rate, etc	●
Other displays: work mode, auto-idle, glow, rearview monitor, operating conditions, etc	●
35 languages selection	●

LIGHTS	ZX210LC-7H
Additional boom LED light with cover	●
Additional cab roof front LED lights	●
LED lights for camera (side and rear view camera)	●
Rotating lamp	○
2 working LED lights	●

UPPER STRUCTURE	ZX210LC-7H
AERIAL ANGLE (270-degree view camera system)	●
Batteries 2 x 126 Ah	●
Body top handrail	●
Control pattern changer (ISO / BH)	●
Counterweight 10,692 lb (4 850 kg)	●
Fuel level float	●
HD undercover	○
Hydraulic oil level gauge	●
Lockable fuel refilling cap	●
Lockable machine covers	●
Lockable tool box	●
Platform handrail	●
Side view mirror (right and left)	●
Skid-resistant plates	●
Swing parking brake	●
Undercover	●
Utility space	●
2 way battery disconnect switch	●

UNDERCARRIAGE	ZX210LC-7H
Bolt-on sprocket	●
Greasing type track adjuster	●
Reinforced track links with pin seals	●
Shoe: 32" (800 mm) triple grouser	●
Towing hole for light weight object	●
Track undercover	○
Travel direction mark on track frame	●
Travel motor covers	●
Travel parking brake	●
Upper and lower rollers	●
3 track guards (each side)	●
4 tie down brackets	●

FRONT ATTACHMENTS	ZX210LC-7H
Arm 9' 7" (2.91 m)	●
Arm tip remote lubrication	●
Casted bucket link A	●
Centralized lubrication system	●
Dirt seal on all bucket pins	●
Flanged pin	●
HN bushing	●
Lower arm reinforcement	●
Reinforced bucket link B	●
Reinforced resin thrust plate	●
WC (tungsten-carbide) thermal spraying	●

ATTACHMENTS	ZX210LC-7H
Accessories for 2 speed selector	○
Additional pump (13.2 gal (50 L)/min)	○
Assist piping	○
Auxiliary hydraulic piping (straight-short piping)	○
Auxiliary hydraulic piping	●
Pilot accumulator	○

MISCELLANEOUS	ZX210LC-7H
ConSite	○
Global e-Service	●
Onboard information controller	●
Satellite communication device	○
Standard tool kit	●
Travel alarm	●

Standard and optional equipment may vary by country, so please consult your Hitachi Construction Machinery Americas Authorized local dealer for details.

* Engine oil and hydraulic oil monitoring sensor.



HITACHI

Reliable Solutions



REPUTATIONS ARE
BUILT ON IT.

Hitachi Construction Machinery Americas Inc. is a leading provider of construction and mining machinery services and solutions in North and Latin America. Our manufacturing facilities are located in Banshu, Ryugasaki, Tierra, Hitachinaka, and Tsuchiura, Japan, while our U.S. corporate office is in Newnan, Georgia. Our experienced team of professionals is well-equipped to design, engineer, manufacture, and service your machinery.

Through our long-term commitment to maintaining a leadership position in technology, service, and support, we support an extensive network of independent, local dealers focused on providing you with knowledgeable and experienced sales, service, and parts personnel — all backed by our dedicated support teams.

Your Hitachi Construction Machinery Americas authorized local dealer has the resources, expertise, and personnel to work with you to ensure that you receive the most benefit from your investment. You can also utilize carefully designed programs and services in conjunction with extensive digital resources. Our focus is entirely on supporting you, your business, and your machinery.

If you are searching for a reliable partner for your construction machinery needs, we invite you to explore our offerings and experience the difference with Hitachi Construction Machinery Americas.

Machines representative of global product. Options may not be available in all markets. Prior to operating this machine, including satellite communication system, in a country other than a country of its intended use, it may be necessary to make modifications to it so that it complies with the local regulatory standards (including safety standards) and legal requirements of that particular country. Please do not export or operate this machine outside the country of its intended use until such compliance has been confirmed. Please contact your Hitachi Construction Machinery Americas authorized local dealer in case of questions about compliance. These specifications are subject to change without notice. Illustrations and photos show the standard models, and may or may not include optional equipment, accessories, and all standard equipment with some differences in color and features. Before use, read and understand the Operator's Manual for proper operation.